

Specifications	
Chamber Size (L x W x H)	56" x 34" x 12" (1422 x 864 x 305 mm)
Effective Length	48" (1219 mm)
Chamber Storage	51 gal (193 L)
Sidewall Height	8.5" (216 mm)
Open Bottom Area	9.8 ft <sup>2</sup> (0.9 m <sup>2</sup> )
Weight	14.5 lbs (6.6 kg)

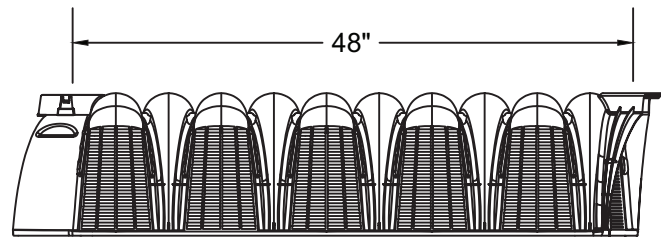
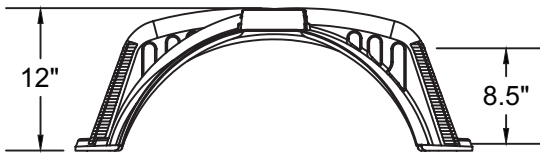
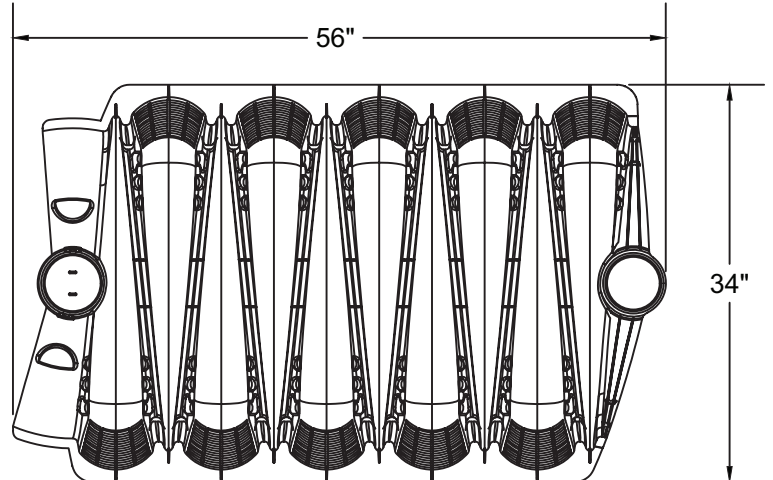

**CHAMBER LOADING**

Chambers meet H-10 loading requirements which support axle loads up to 16,000 lbs when installed with 12" minimum cover over the chamber.

**CHAMBER COUPLING**

Chamber coupling supports a pivot of 10 degree left or right. Each coupler has a locking mechanism and the capability to support a 4" inspection port. The direction of installation is located on top of the chamber.

End Cap Specifications	
End Cap Size (L x W x H)	16" x 29" x 12" (406 x 737 x 305 mm)
Effective Length	13" (330 mm)
Invert Elevations	0.5", 6", 7", 12"
End Cap Storage	7 gal (27 L)
Weight	2.6 lbs (1.2 kg)

